

# CNC HORIZONTAL MACHINING CENTER

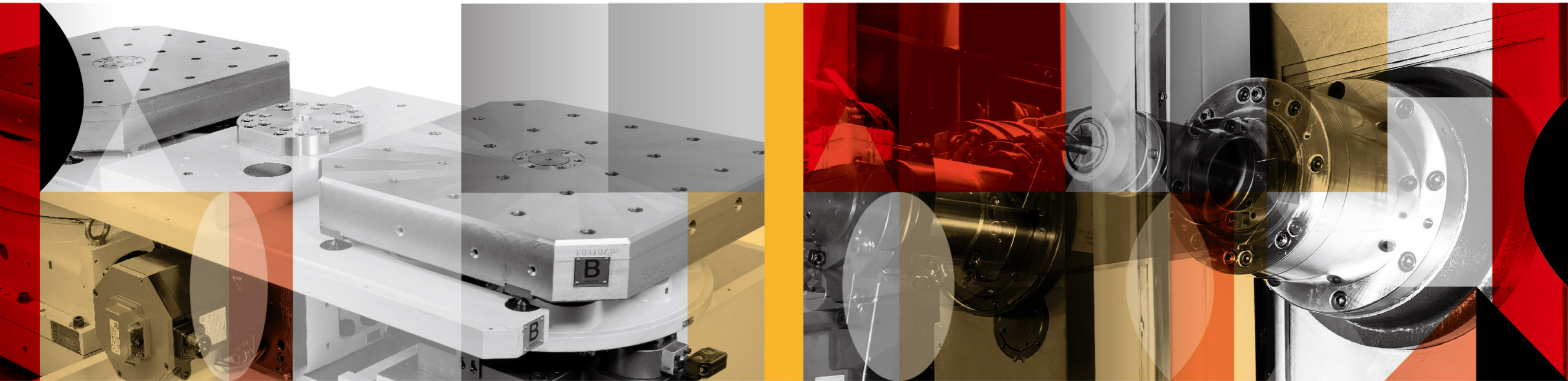

**MANFORD MACHINERY CO., LTD.**

No.8, Jingke 8th Road, Taichung Precision Machinery Park,  
Taichung 40852, Taiwan  
TEL: 886-4-23586808  
FAX: 886-4-23586899  
Email: manford@manford.com.tw  
www.manford.com.tw

ACW 2018.03.500E

## HM series

The Combination of Efficiency and Productivity

[www.manford.com.tw](http://www.manford.com.tw)



# CNC Horizontal Machining Center

(APC series)

## Features

- Reciprocating automatic pallet change
- Roller type linear ways on X, Y, Z axes
- Full HMC performance by servomotor package
- (HM-400/HM-500/HM-630 40 tools Std.)
- 60 / 90 tool chain type magazine (Opt.)
- Table divide minimum angle: 0.001°(HM-400 Std.)
- Direct drive spindle (HM-400 / HM-500/HM-630)

## HM-400

- X / Y / Z Travels: 630 / 630 / 630 mm
- Work Table: 400 x 400 mm
- BT-40 Spindle Speed: 10,000 rpm
- Direct Drive Spindle
- ATC: 40T

## HM-500

- X / Y / Z Travels: 800 / 725 / 725 mm
- Work Table: 500 x 500 mm
- BT 40 Direct drive / 10,000rpm or BT-50 Spindle / 6,000 rpm opt.
- Direct Drive Spindle
- ATC: 40T

## HM-630

- X / Y / Z Travels: 1,000 / 850 / 950 mm
- Work Table: 630 x 630 mm
- BT 40 Direct drive / 10,000rpm or BT-50 Spindle / 6,000 rpm opt.
- Direct drive spindle
- ATC: 40T (60T opt.)



# Built With Passion for Hi-tech Engineering

## HM-630

### Twin Ball Screws + Step Structure

- Developed for high precision and high reliability production, the Manford horizontal machining center is the best equipment for automobile, small or medium petroleum-chemical components, medical parts, rail road as well as aerospace industries.

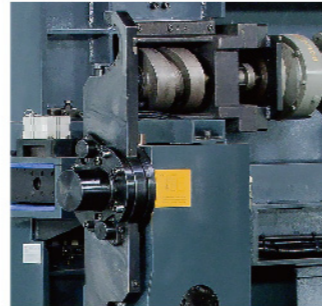

### Step Structure for X-axis Moving Column

- Two linear guide ways are deployed on the machine base in different planes. The high-low step structure effectively reduces the machine column's unnecessary mass and increases dynamic rigidity. Compared to the traditional flat base, Manford's sturdy design assures the optimum performance for productivity and accuracy.

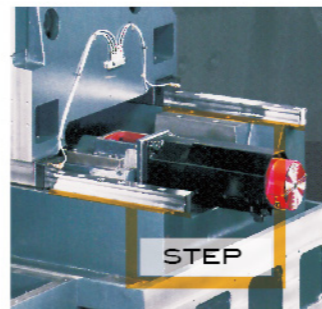

### Engineered for Heavy Duty & Precision Performance

- The vertical Y-axis employs a unique Twin-ball Screw design; The powerful system replaces the traditional counter-balance mechanism, offering an extraordinary platform to support high speed vertical reciprocating movement of the head assembly.

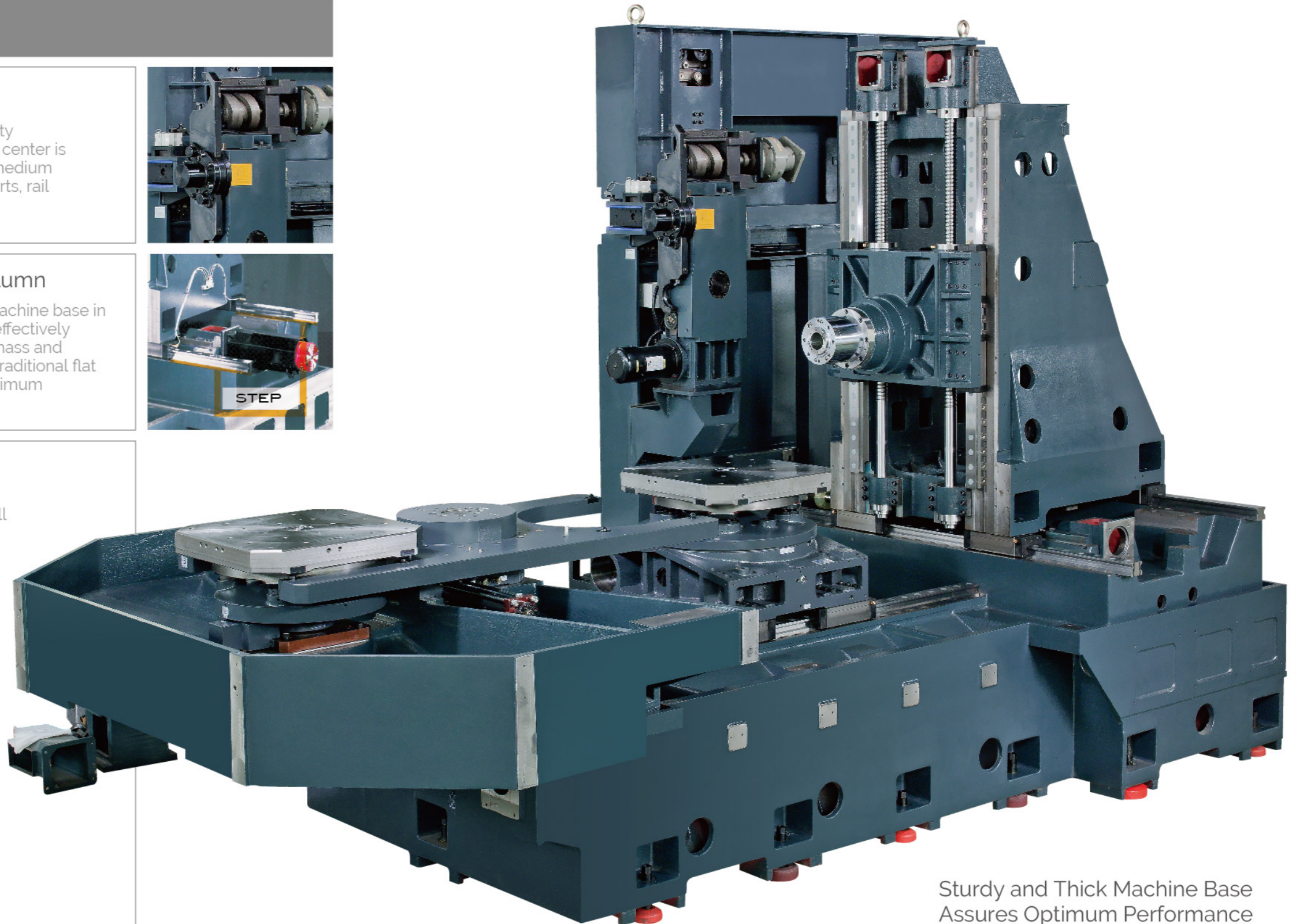
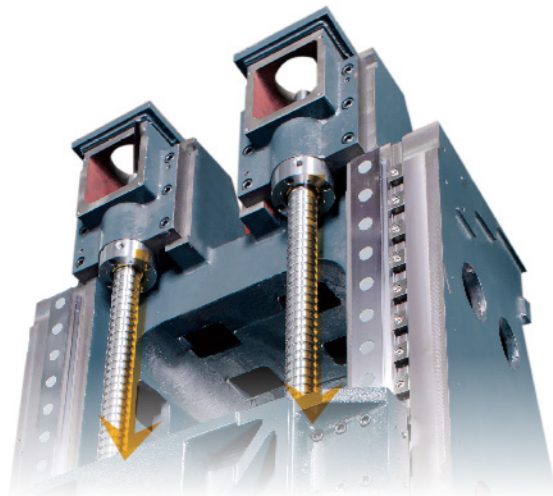

Sturdy and Thick Machine Base Assures Optimum Performance

# CNC Horizontal Machining Center

(APC series)

## Features

- Traveling column construction
- Reciprocating automatic pallet change
- Roller type linear ways on X, Y, Z axes
- Full HMC performance by servomotor package
- 60 / 90 tool chain type magazine (Opt.)  
(HM-800/1000 40 tools Std.)
- High torque performance, Japan brand Gear head  
(HM-800~HM-1000)
- Hiwin ball screw coolant system (HM-800/1000 Std.)

## HM-800

- X / Y / Z Travels: 1,270 / 1,050 / 1,050 mm
- Work Table: 800 x 800 mm
- BT-50 Spindle / 6,000 rpm
- Gear Drive Spindle
- ATC: 40T (60T opt.)

## HM-1000

- X / Y / Z Travels: 1,530 / 1,250 / 1,200 mm
- Work Table: 1000 x 1000 mm
- BT-50 Spindle / 6,000 rpm
- Gear Drive Spindle
- ATC: 40T (60T opt.)



# Unique Structure Design Exhibits Perfect Rigidity and Stability

HM-800/1000

## Features

- The major structural parts are ladle and box type integrated construction to fully overcome the cutting "Blind Rigidity" problem.
- Three axes are mounted with heavy duty roller type linear guide ways, featuring heavy load resistance and rapid traverse.
- The structural parts are symmetrical construction combined with "V" shape rib reinforcement that ensures they will remain deformation-free even after a long time.
- The structural parts are manufactured from high quality cast iron, tempered for stress relief.
- The advanced finite element analysis software is applied for simulating structural stress. This assures the best possible machine rigidity, stability and dampening capacity.

## Integrated Auto Pallet Changing System

- The entire Automatic Pallet Changing (APC) system is installed on the machine base. The 1° index table employs a high precision curve clutch for accurate positioning, presenting excellent positioning as well as repeatability accuracy. It is easy to re-calibrate the pallet position in clockwise or counter-clockwise direction in case there is unexpected crash or system malfunction occurs. The continuous 0.001° index, or B axis is optional.

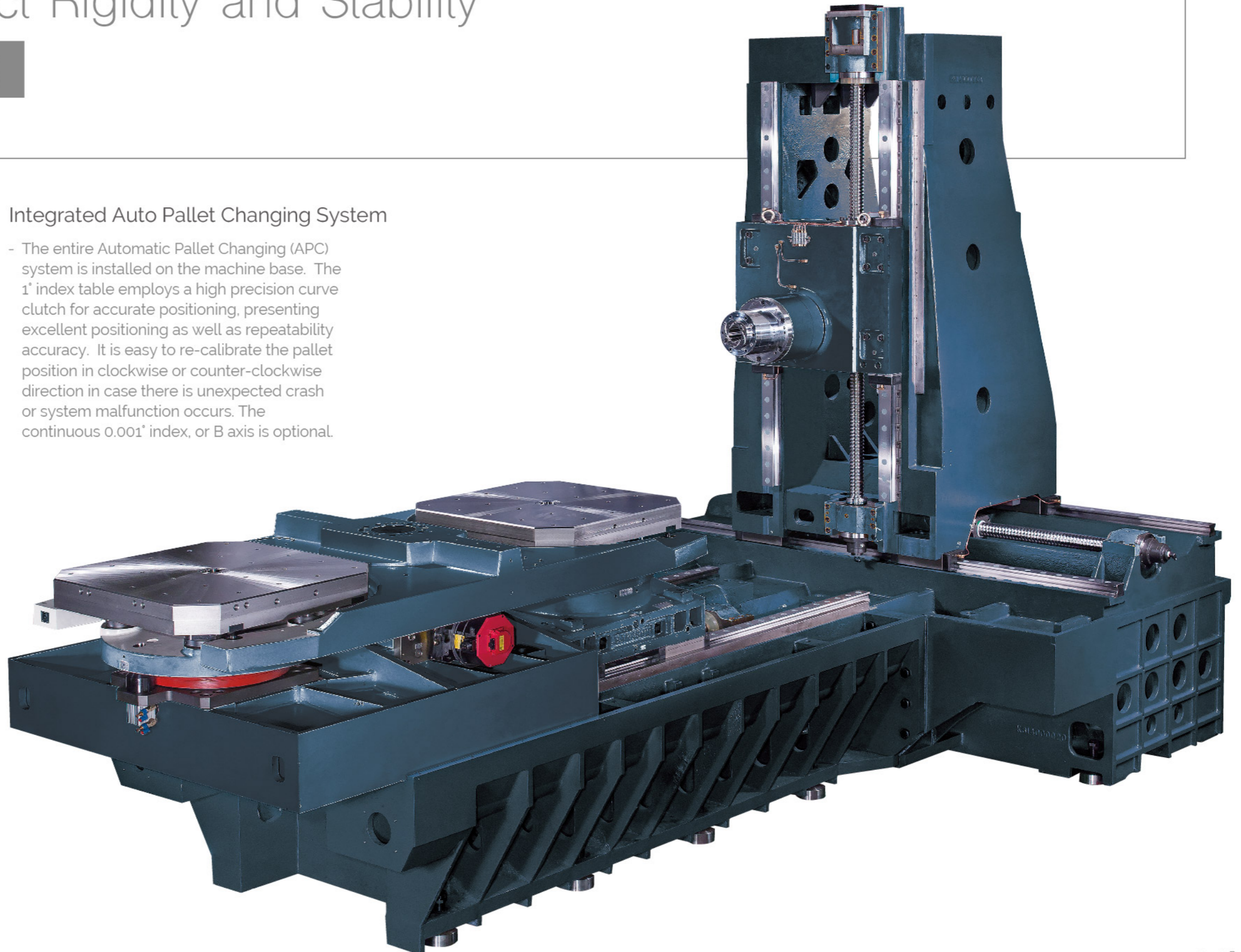

# The Combination Of Flexibility, High Productivity and Profitability

## Rotary Type - APC

- The entire Automatic Pallet Changing (APC) system is installed on the machine base. The 1° index table employs a high precision curve clutch for accurate positioning, presenting excellent positioning as well as repeatability accuracy. It is easy to re-calibrate the pallet position in clockwise or counter-clockwise direction in case there is unexpected crash or system malfunction occurs. The continuous 0.001° index, or B axis is optional.

## Air Blast on Positioning Cones

- The Pallet is fitted on 4 positioning cones. Before pallet positioning, the 4 positioning cone surfaces are cleaned by air blast, allowing the pallet to achieve higher stability and positioning accuracy.

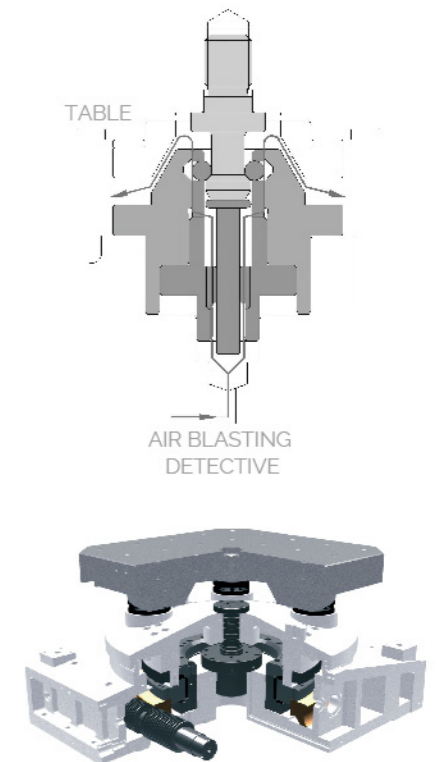
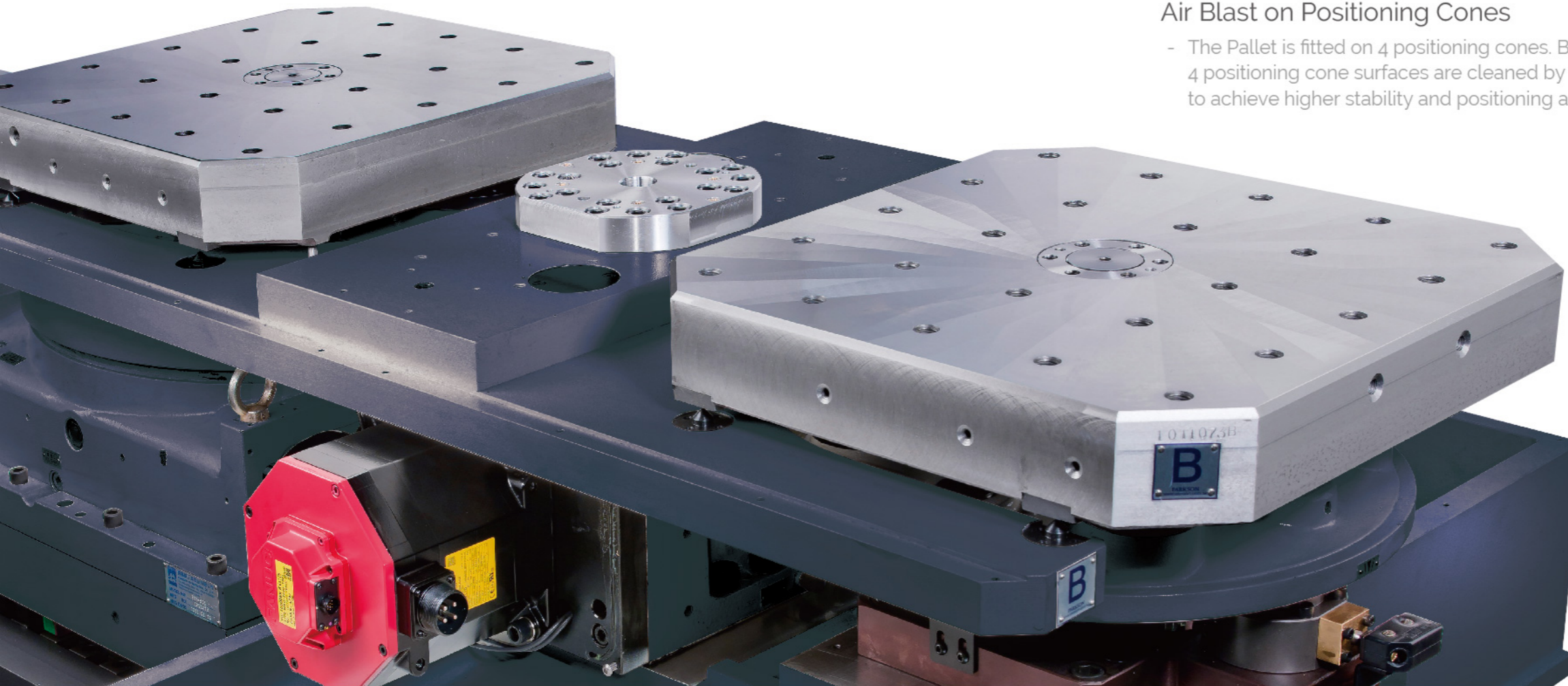

## Rotary Type - APC 1° Indexing Table Hirth Coupling

MODEL	HM-500	HM-630	HM-800	HM-1000
Pallet size	500 x 500 mm	630 x 630 mm	800 x 800 mm	1000 x 1000 mm
Accuracy	± 5 sec	± 5 sec	± 5 sec	± 5 sec
Repeatability	± 1.5 sec	± 1.5 sec	± 1.5 sec	± 1.5 sec
Tilting moment	7,800 Nm	15,000 Nm	28,000 Nm	28,000 Nm
High clamping force	5,500 Nm	8,000 Nm	10,000 Nm	10,000 Nm

- MH-500/630 four cones clamping system clamping force at 35,000N
- MH-800/1000 4 large size taper cones provide 70,000N clamping force.
- Dual-lead 0.001° worm shaft worm wheel set. (high positioning & repeatability accuracy)



## 0.001° NC Rotary Table opt.

MODEL	HM-400	HM-500	HM-630	HM-800	HM-800
Pallet size	400 x 400 mm	500 x 500 mm	630 x 630 mm	800 x 800 mm	1000 x 1000 mm
Indexing accuracy	± 7.5 sec	± 7.5 sec	± 7.5 sec	± 7.5 sec	± 7.5 sec
Repeatability	± 3 sec	± 3 sec	± 3 sec	± 3 sec	± 3 sec
Tilting moment	4,000 Nm	4,000 Nm	9,000 Nm	19,000 Nm	19,000 Nm
High clamping force	2,500 Nm (Std.)	3,000 Nm (Opt.)	5,000 Nm (Opt.)	8,000 Nm (Opt.)	8,000 Nm (Opt.)

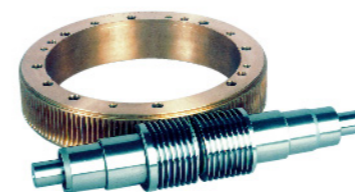

# Direct Drive Spindle

- High power high torque motor is direct coupled with the spindle. The design features no transmission belt or gear that generate heat affecting the entire head stock's metallic thermal stability, and accuracy. Together with the oil cooling system, the direct drive spindle displays outstanding power and accuracy with low noise, low vibration, low temperature rising performance to meet all different kinds of cutting conditions. Built-in motorized spindle is optional.



## Coolant Through Spindle

- The coolant through spindle function is available via a rotary joint between the motor and spindle. The high pressure coolant boosts especially deep hole drilling performance for multiple times, and also extends the life time of cutting tools.

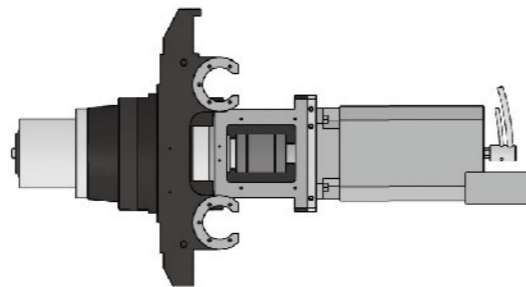

## BT-50 Gear Head Spindle (HM-800/1000 Std.)

- The spindle is directly transmitted by gears, featuring extraordinary rigidity that provides high torque during low speed range, suitable for heavy duty cutting. Low noise and low vibration.

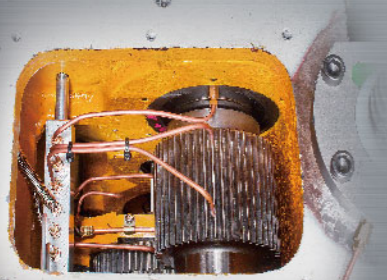

## Spindle Speed / Output Diagram

### Taper.40

HM-400/HM500

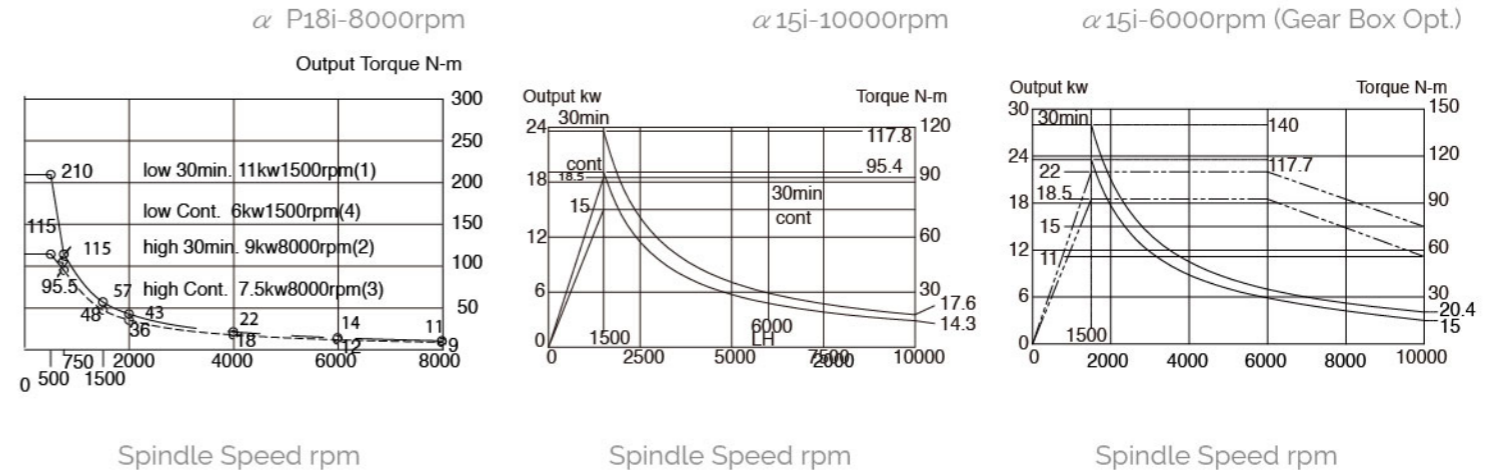

### Taper.50

HM-500/HM-630

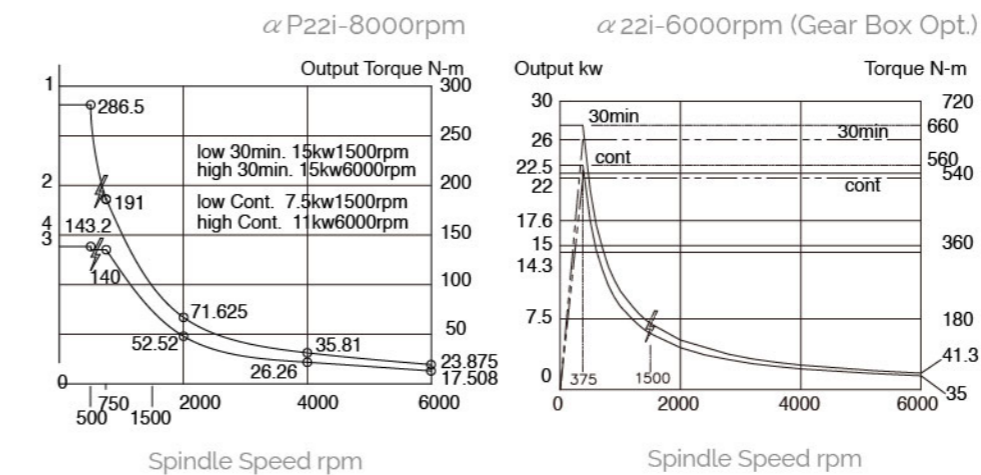

### Taper.50

HM-400 / 500/630 / 800 / 1000 Gear Head Spindle

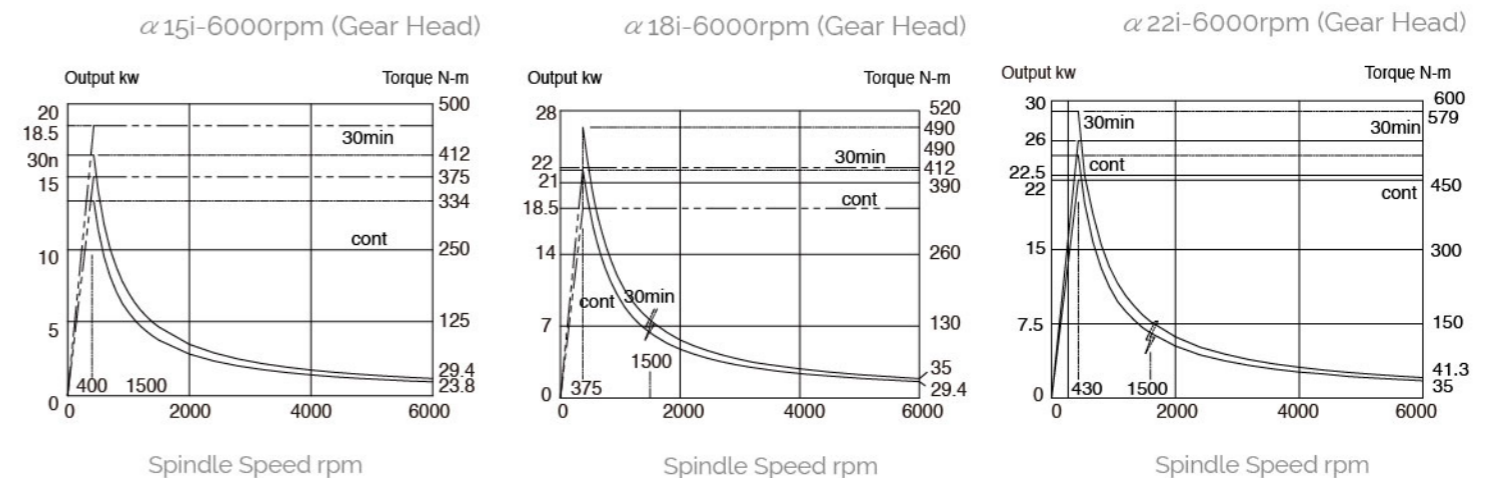

# Automatic Tool Changer

- The automatic tool magazine facilitates the versatility of the machine's applications. Various magazine capacities of 40, 60, 90 or 120 tools are available to choose from. The tool magazine is installed in parallel direction to the spindle; adopting larger magazine occupies limited space only.
- Fast and stable tool change motions save non-cutting time and increases efficiency. The spindle features floating tool release to extend the service life of the spindle bearings.

HM-630

- Tool Storage Capacity:  
#50 x 40 Tools

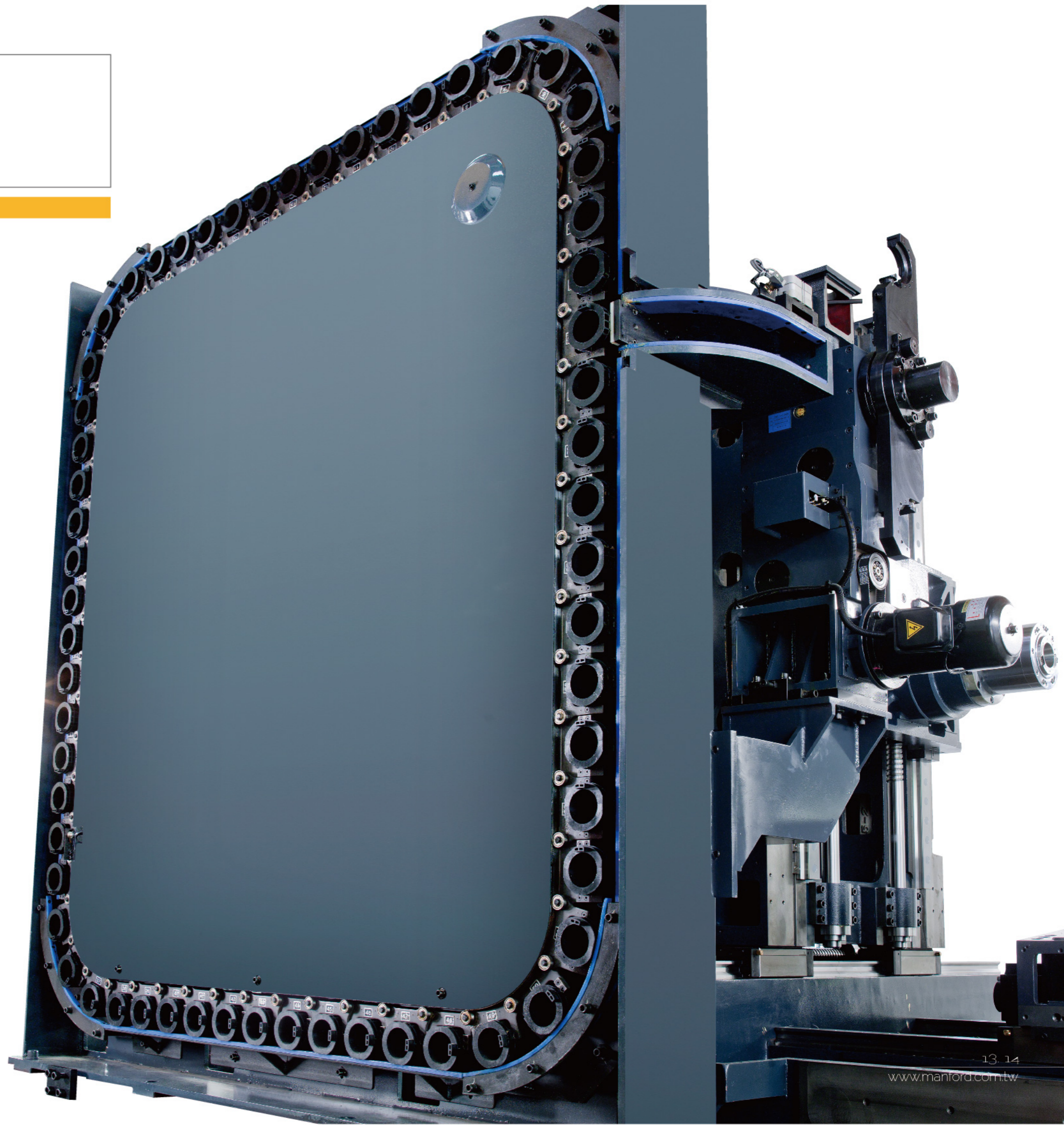



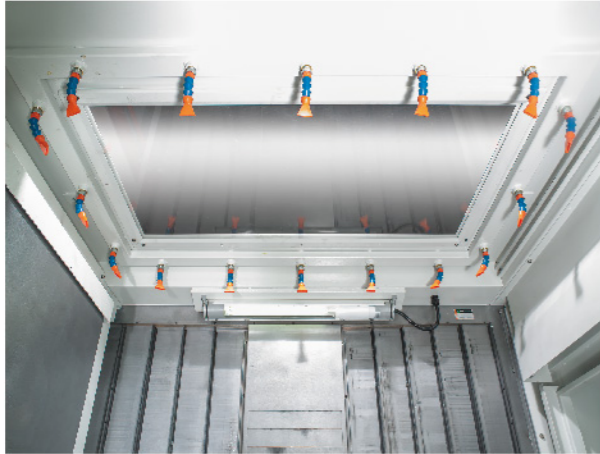

- Large flow coolant shower nozzles are deployed on the top lid of the cutting area. It is capable of removing metal chips as well as heat from the cutting area, maintaining stable and accurate machining conditions.

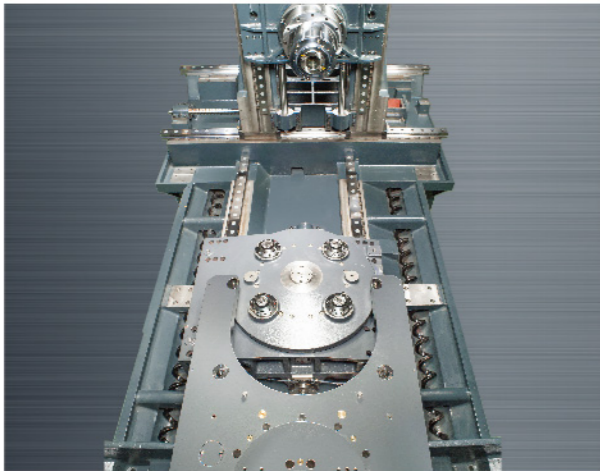

#### Highly Efficient Chip Disposal

- The standard twin chip augers are installed on the machine base.



#### Cts Coolant Through Spindle Device (Cts-20 / 30 / 50 Bar Opt.)

- 20-bar coolant through spindle with filtration unit features mighty performance that the cutting efficiency is increased, and the tool life time is extended.

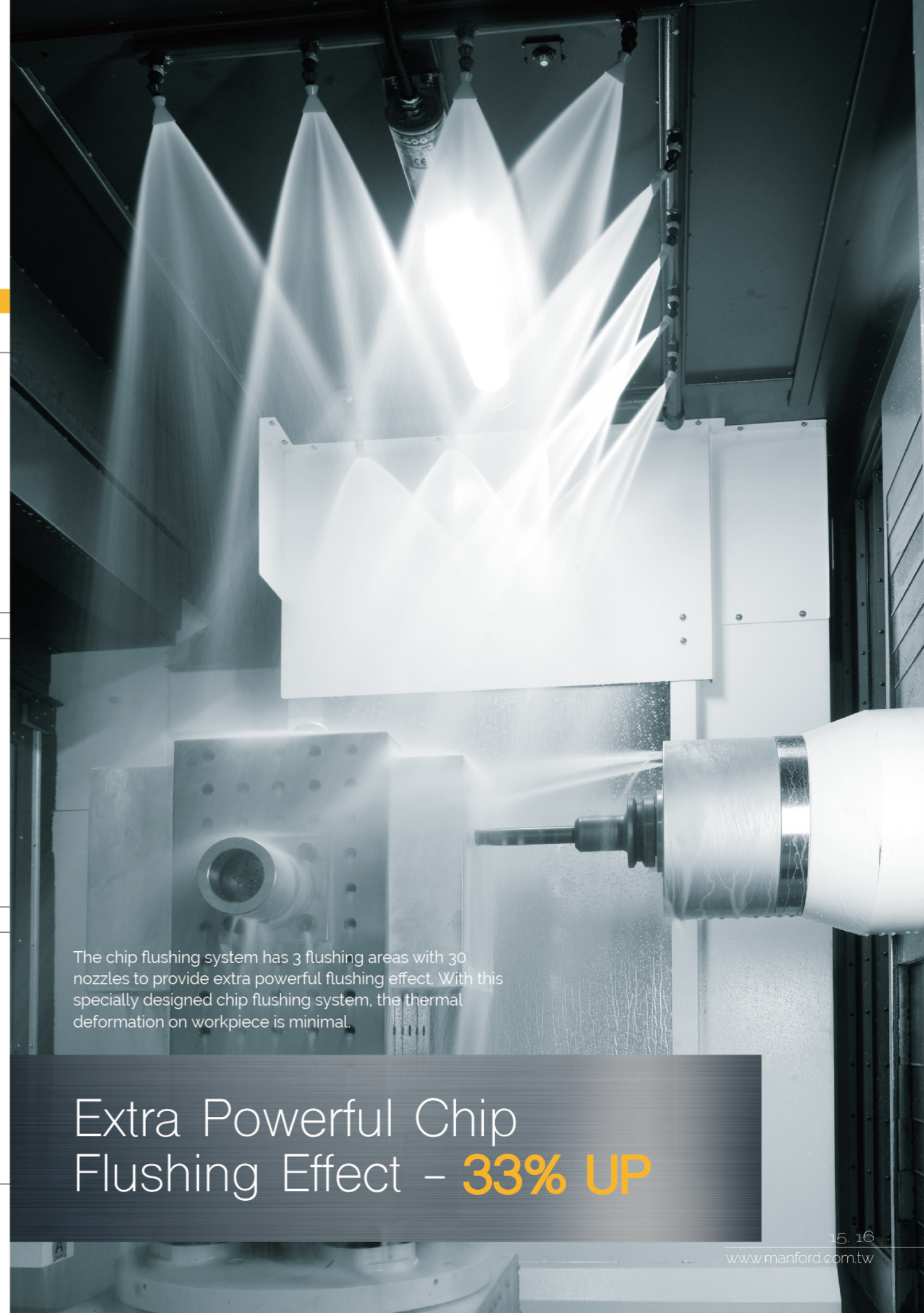

The chip flushing system has 3 flushing areas with 30 nozzles to provide extra powerful flushing effect. With this specially designed chip flushing system, the thermal deformation on workpiece is minimal.

Extra Powerful Chip  
Flushing Effect – **33% UP**

# HM-630 Linear Guideways

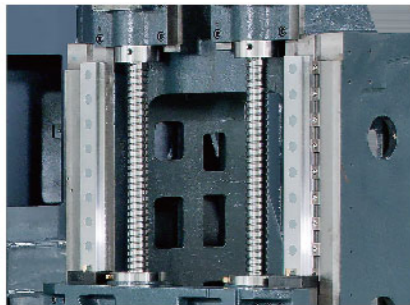

- Roller type linear guide ways are used on all linear axes. For added support, each roller shoe is internally preloaded diagonally in a cross configuration.

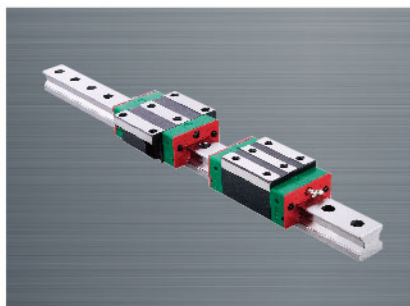

## Rigid Roller Type Linear Way

- The Linear Motion Guideways feature low friction and are free from stick-and-slip problems, such the characteristics are especially suitable for high speed 3D cutting and finishing. The quality of workpiece surface is increased; the need of manual polishing of workpiece surfaces is reduced.

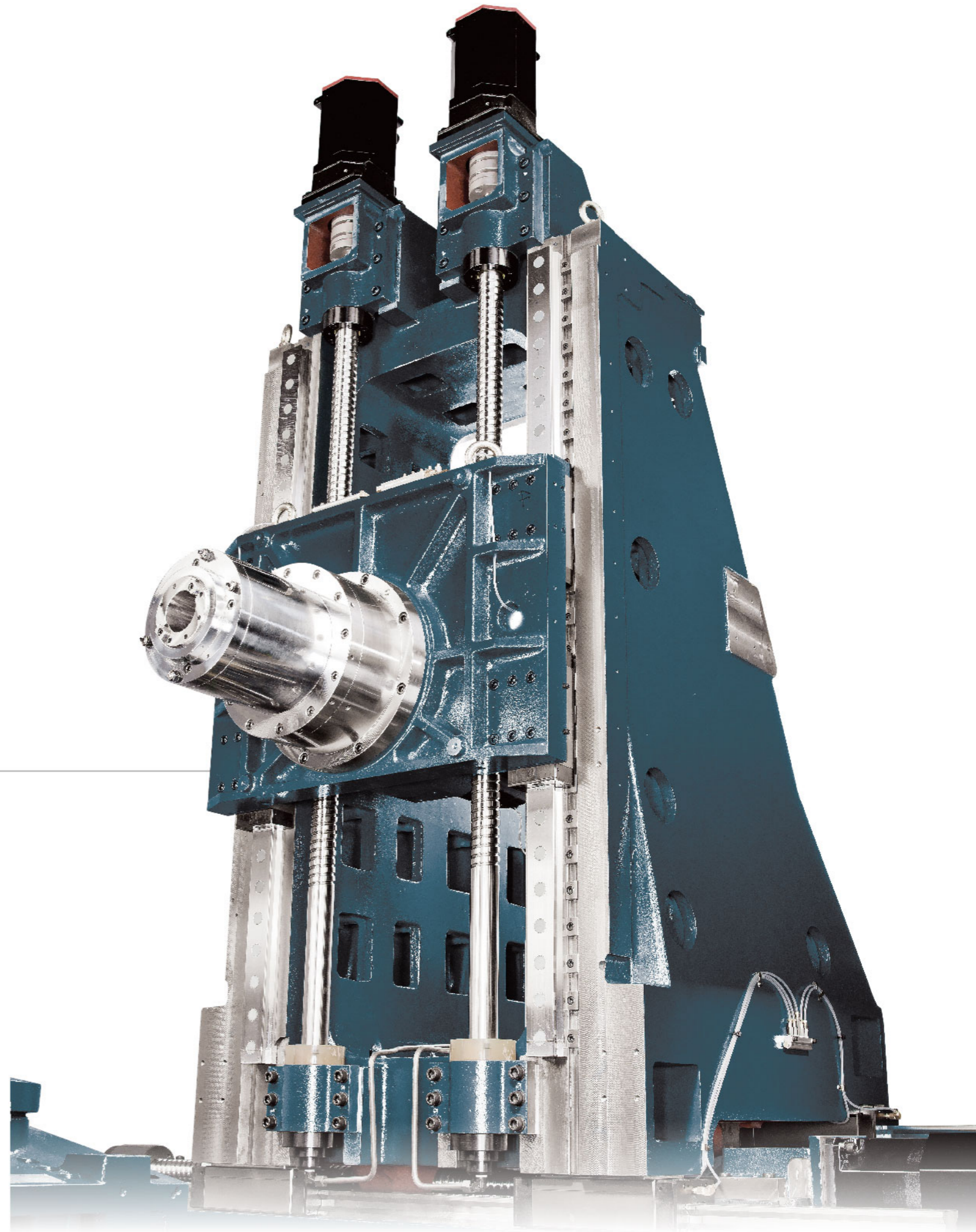

## LHL VS Oil Cost Comparison (Every Year) Opt.

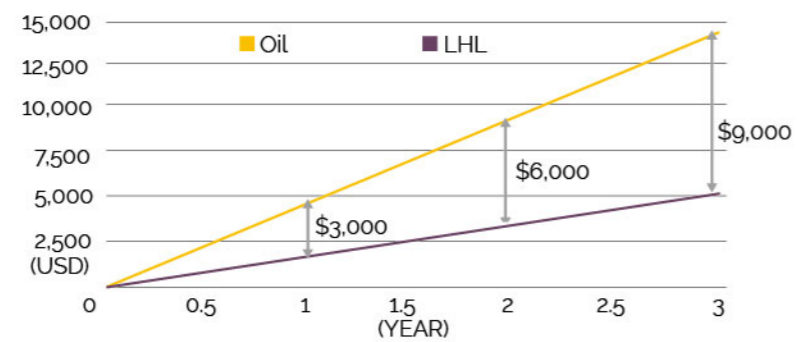

- Compared to high velocity lubrication oil, the med-pressure grease system uses 90% less oil, and the pump motor consumes 80% less electricity.



# Apc Specifications - Excellent Working Space

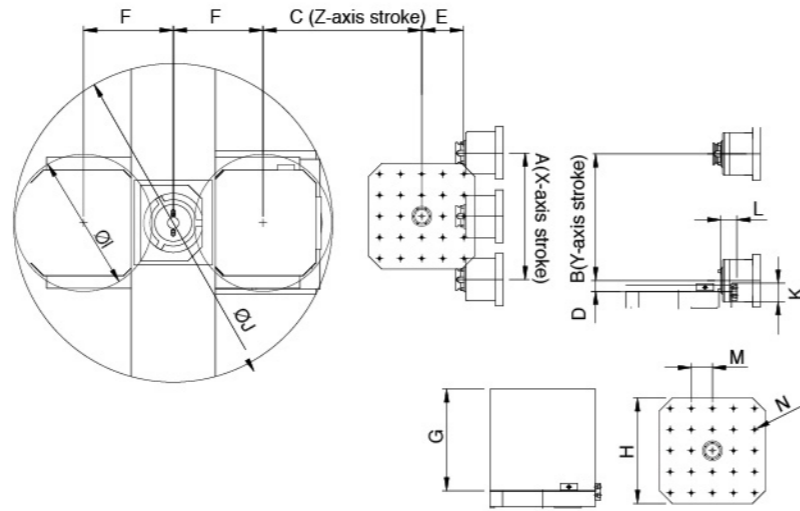

## Interference Area Point

INTERFERENCE DIAGRAM	MH-400 (BT.40)	MH-500 (BT.40)	MH-500 (BT.50)	MH-630	MH-800	MH-1000
A	630	800	800	1020 (40")	1270 (50")	1530 (60")
B	630	725	725	850	1050	1250
C	630	725	725	890	1050	1200
D	50	50	50	70	50	50
E	130	150	200	200	230	270
F	400	475	475	615	800	800
G	750	825	825	950	1150	1350
H	400 x 400	500 x 500	500 x 500	630 x 630	800 x 800	1000 x 1000
I	560	630	630	870	1110	1300
J	1360	1580	1580	2100	2710	2900
K	85	85	110	90	110	110
L	90	125	75	140	195	305
M	80	100	100	125	160	160
N	24-M10 x P1.5 x 20	24-M16 x P2.0	24-M16 x P2.0	24-M16 x P2.0	24-M16 x P2.0	24-M16 x P2.5

# Machine Dimensions

## HM-400

NO.#40  
40T

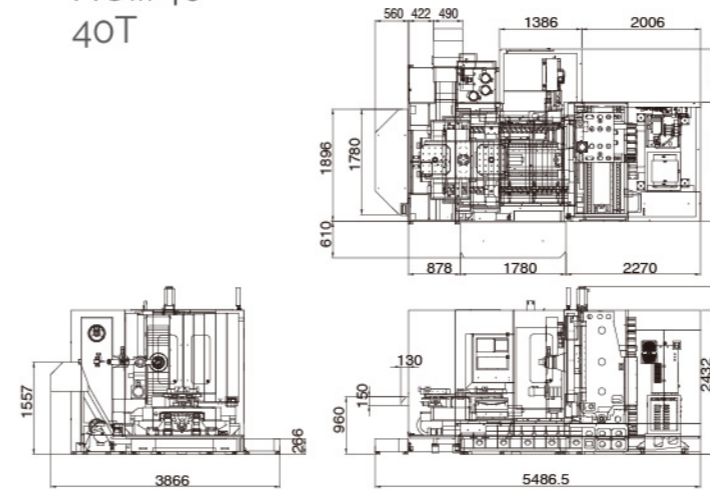

## HM-500

NO.#40  
60T

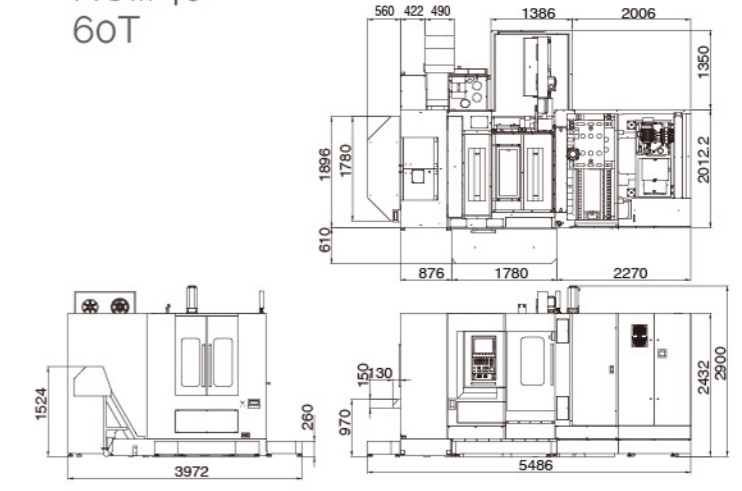

## HM-500

NO.#50  
60T

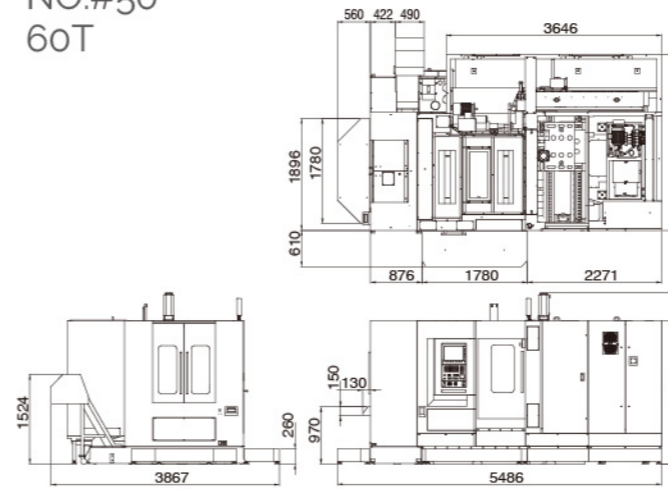

## HM-630

NO.#50  
60T

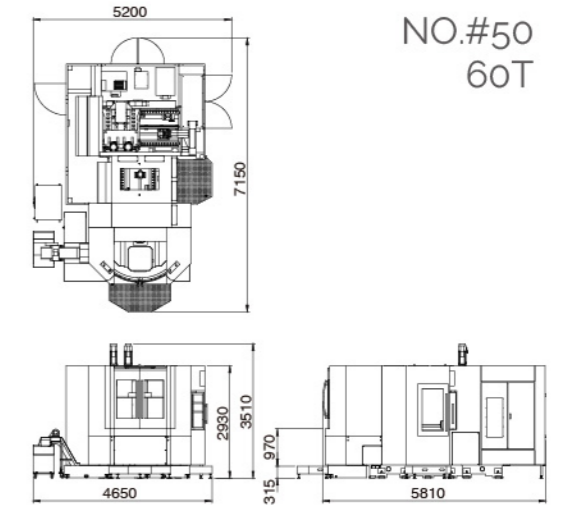

## HM-800

NO.#50  
60T

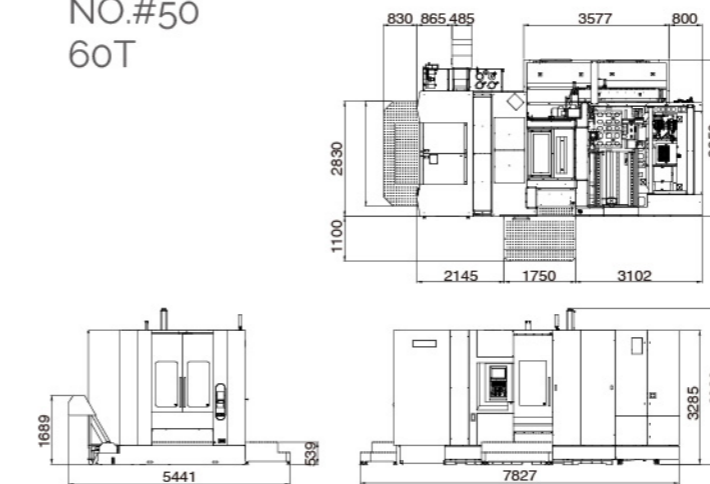

## HM-1000

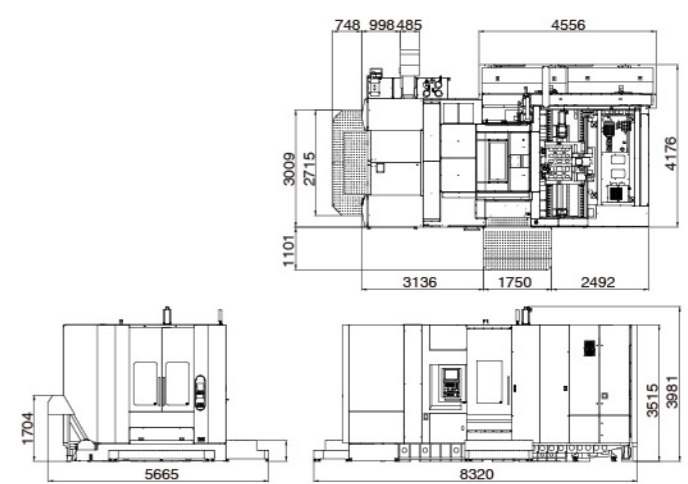

# Specifications

Model		UNIT	HM-400 (40)	HM-500 (40)	HM-500 (50)	HM-630 (50)	HM-800 (50)	HM-1000 (50)
Travel	X - axis travel	mm	630	800	800	1000	1270	1530
	Y - axis travel	mm	630	725	725	850	1050	1250
	Z - axis travel	mm	630	725	725	950	1050	1200
	Spindle center to work table surface	mm	50 ~ 680	50 ~ 775	50 ~ 775	100 ~ 950	50 ~ 1100	50 ~ 1300
	Spindle nose to work table center	mm	130 ~ 760	150 ~ 875	200 ~ 925	150 ~ 1100	230 ~ 1280	270 ~ 1470
Table	Table surface to floor	mm	1100	1100	1100	1300	1320	1360
	Table size	mm	400 x 400	500 x 500	500 x 500	630 x 630	800 x 800	1000 x 1000
	T - slot / Bolt Spec.	mm	24-M10 x P1.5 x 20	24-M16 x P2.0	24-M16 x P2.0	24-M16 x P2.0	24-M16 x P2.0	24-M20 x P2.5
	Max table load	kg	400	500	500	1200	2000	2000
	Index precision	deg	0.001°	1° (OPT. 0.001° / 5°)	1° (OPT. 0.001° / 5°)	1° (OPT. 0.001° / 5°)	1° (OPT. 0.001° / 5°)	1° (OPT. 0.001° / 5°)
Spindle	Spindle taper		BT-40	BT-40	BT-50	BT-50	BT-50	BT-50
	Method of spindle		DDS	DDS	DDS	DDS	Gear Head	Gear Head
	Spindle diameter	mm	Ø70	Ø70	Ø100	Ø100	Ø100	Ø100
	Spindle speed	rpm	10000	10000	6,000	6000	6000	6000
Feedrate	Spindle motor (cont / 30 min)	kw	15/18.5	15/18.5	15/18.5	15/18.5 / 22/26	15/18.5 / 22/26	15/18.5 / 22/26
	3 - axes cutting feedrate	mm / min	1 ~ 10000	1 ~ 10000	1 ~ 10000	1 ~ 6000	1 ~ 6000	1 ~ 6000
	3 - axes rapid feedrate	M/min	36 (48 opt.)	30 (36 opt.)	30 (36 opt.)	24 (30 opt.)	15 / 15 / 12	15 / 15 / 12
	3 - axes min. setting unit	mm	0.001	0.001	0.001	0.001	0.001	0.001
	Repeat accuracy	mm	0.01	0.01	0.01	0.01	0.01	0.01
	Position accuracy	mm	0.006	0.006	0.006	0.006	0.006	0.006
ATC	Tool selec	pcs	40 (60 opt.)	40 (60 opt.)	40 (60 opt.)	40 (60 opt.)	40 (60 opt.)	40 (60 opt.)
	Max. tool diameter x length		Ø80 x 300	Ø85 x 300	Ø125 x 400	Ø120 x 400	Ø125 x 600	Ø125 x 600
	Max. tool weight	kg	10	10	20	20	20	20
	Tool change time (t - t)		1.6 (60 HZ)	1.6 (60 HZ)	2.9 (60 HZ)	3 (60 HZ)	2.9 (60 HZ)	2.9 (60 HZ)
APC	Number of pallets	PCS	2	2	2	2	2	2
	Method of pallet change	type	ROTARY	ROTARY	ROTARY	ROTARY	ROTARY	ROTARY
	Pallet change time	sec	8 SEC	8 SEC	8 SEC	14-16 SEC	12 SEC	18 SEC
Other	Floor space (L x W x H)	mm	4713 x 3056 x 2735	4835 x 3227 x 2957	4835 x 3227 x 2957	6664 x 4175 x 3632	7500 x 4200 x 3800	8320 x 4230 x 5665
	Machine weight (N.W / G.W)	kg	11500 / 13500	13500 / 16500	16000 / 19000	2000	29000 / 33000	31000 / 35000
	Power capacity require	KVA	40	40	40	50	50	50
	Shipment Require (Suggest)	inch	40" HQ	40" HQ	40" HQ	40" FR + 40" HQ	40" FR + 40" HQ	40" FR + 40" HQ

- Specifications subject to change without prior notice.

## Standard Accessories

- Rotary type automatic pallet changer
- 1° indexing rotary table (HM-400 Std. 0.001°)
- Chain type chip conveyor with cart
- Rigid roller type linear guide way system
- Spindle curtain coolant
- Spindle oil cooler
- Heat exchanger for electrical cabinet
- 3 areas powerful chip flushing system
- Automatic lubrication system
- Fully enclosed splash guard

- Mitsubishi or Fanuc control
- Leveling bolts and pads
- Tool box with tools
- Operation and maintenance manual
- Transformer (Export only) and Export packing

## Optional Accessories

- 0.001° or 5° indexing rotary table (HM-400, 0.001° Std.)
- 60, 90, 120 tools chain type magazine
- BT-40, 10,000 ~ 24,000 rpm direct drive (HM-400 / 500)
- BT-50, 8,000 ~ 12,000 rpm direct drive (HM-500)
- BT-50, 8,000 or 10,000 rpm direct drive (HM-630-1000)
- Coolant through spindle (CTS-20 / 30 / 50 / 70 bar)
- 3 axes linear scales
- Oil skimmer
- Air conditioner for electrical cabinet
- Automatic tool length measuring device

- Automatic workpiece measuring device
- Coolant through tool holder 20/50 bar (without tool holder)
- CE
- SIEMENS, HEIDENHAIN, FAGOR controller
- Pallet automation system
- High torque Gear box (HM-400 / 500)